

# Lichen Remover

## Operating instructions

FY 2023 ..  
BA 0305251 26-04 V2.0

Translation of operating instructions for the  
Cleaner Lichen Remover

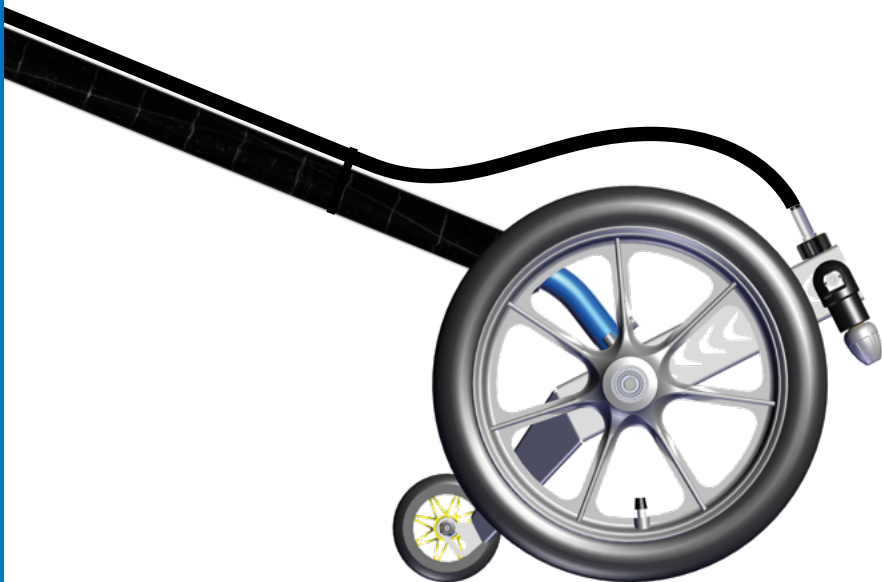







MADE  
IN  
GERMANY



Cleantecs

en

Lichen Remover

 <b>Basics</b> .....	<b>7</b>
Safety information .....	8
Explanatory information .....	9
Overview of the cleaner components .....	10
Tool .....	11
Accessories required for operation .....	11
How does the lichen remover work? .....	12
Components and their function .....	13
Intended use .....	15
Requirements of the system user .....	15
Space requirements .....	15
Performance data in normal operation .....	15
Working width and weight .....	16
Performance limits for operation .....	16
Water quality for operation .....	16
Requirements for the high-pressure cleaner .....	16
EC Declaration of Conformity .....	17
 <b>Safety principles</b> .....	<b>18</b>
For your safety .....	19
 <b>Safe operation</b> .....	<b>22</b>
<b>Working safely</b> .....	<b>23</b>
Selecting a safe starting point .....	23
Awareness of hazards in the working area .....	23
Checking the safety of the modules to be cleaned .....	23
Safety when cleaning .....	23
Check and prepare the high-pressure equipment .....	23
Cordon off access to the work area .....	23

 <b>Commissioning</b> .....	<b>25</b>
<b>Preparing to connect the cleaner</b> .....	<b>26</b>
Unpacking the lichen remover	26
Check lichen remover	26
Transporting the cleaner to the place of use	26
Mounting the VCMO lance	27
Connecting the high-pressure hose to the high-pressure cleaner	27
Fitting the NW6 high-pressure hose	28
Setting the pressure on the high-pressure cleaner	29
Switching the high water pressure on/off	30
Changing the nozzle bar	31
 <b>Operation</b> .....	<b>33</b>
<b>Working with the lichen remover</b> .....	<b>34</b>
What do I need to be aware of when working with a rotor nozzle?	34
Apply the lichen remover	35
Start lichen remover	35
The cleaning process	36
Stop lichen remover	37
Pause cleaning	37
 <b>Decommissioning</b> .....	<b>38</b>
<b>Dismantling the lichen remover</b> .....	<b>39</b>
Dismantling the NW6 high-pressure hose	39
Dismantling the VCMO lance	39
Remove the high-pressure hose from the high-pressure cleaner	40
Transporting lichen remover from the roof	40

 <b>Transport and storage</b>	<b>41</b>
<b>Transporting and storing the cleaner</b>	<b>42</b>
Allow water to run out of the cleaner	42
Cleaner care	43
Preserving the cleaner	43
Lubricating components	43
Making the cleaner winterproof	43
Making the cleaner winterproof	43
 <b>Repairing</b>	<b>44</b>
<b>Rotor nozzle defective</b>	<b>45</b>
Occurring error patterns	45
Corrective measure	45
<b>Replace rotor nozzle</b>	<b>45</b>
Dismantle the rotor nozzle from the nozzle bar	45
<b>Install repair kit</b>	<b>47</b>
Open the pressurised housing	47
Dismantle rotor and bearing	48
Fitting the rotor and bearing	49
Close pressure housing	50
<b>Cleaning or replacing the HP filter</b>	<b>51</b>
Dismantling the HP filter	51
Fitting the HP filter	51
 <b>Disposal</b>	<b>52</b>
<b>What happens to the waste?</b>	<b>53</b>
Packaging	53
Resin for ultra-pure water production	53
Wheels, rotor nozzle covers, rotor nozzle holder housing Profile tube, lance connection, sheet metal parts, rotor nozzle, connection nipple	53



## Notes

Handwriting practice area with a grid of dots and a margin line.



It is **IMPORTANT** that you read these operating instructions **CAREFULLY BEFORE USE** and **RETAIN THEM FOR FUTURE REFERENCE**.

Visit our homepage at regular intervals to check for a more recent version of the operating instructions.

The operating instructions are for...

Lichen remover from year of construction 2023.



# Components and functions of the lichen remover

Here you will find information about:  
Components of the system, tools for maintenance



# Explanation of notices

## Safety information

The information is for your safety. The notices can be found in the general safety section and are always accompanied by an action that requires specific attention.

 **DANGER**

Failure to comply will lead to serious injury or death.

 **WARNUNG**

Failure to comply may lead to serious injury or death.

 **CAUTION**

Failure to comply may lead to injuries.

**NOTICE**

Failure to comply may lead to material damage and impair the function of the product.

*Note: ...*

Additional information about product operation.



## Explanatory information

This information can be found in the grey shaded area in a diagram. It helps you to find the right diagram for the heading in the text, understand the details better, follow steps, understand movements and identify the position.

### Image title

The title of the image indicates the **text** to which the figure belongs.

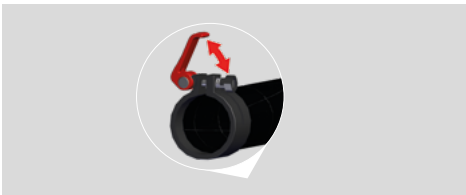

The detailed view highlights areas that are important.

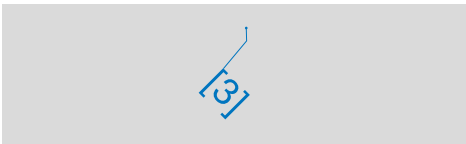

The numbers on the figures refer to the steps in the explanatory text. You always start again on a page from [1].

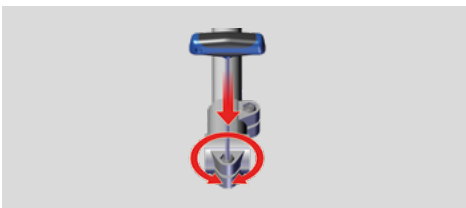

The red arrows always indicate a movement.



### Overview of the cleaner components

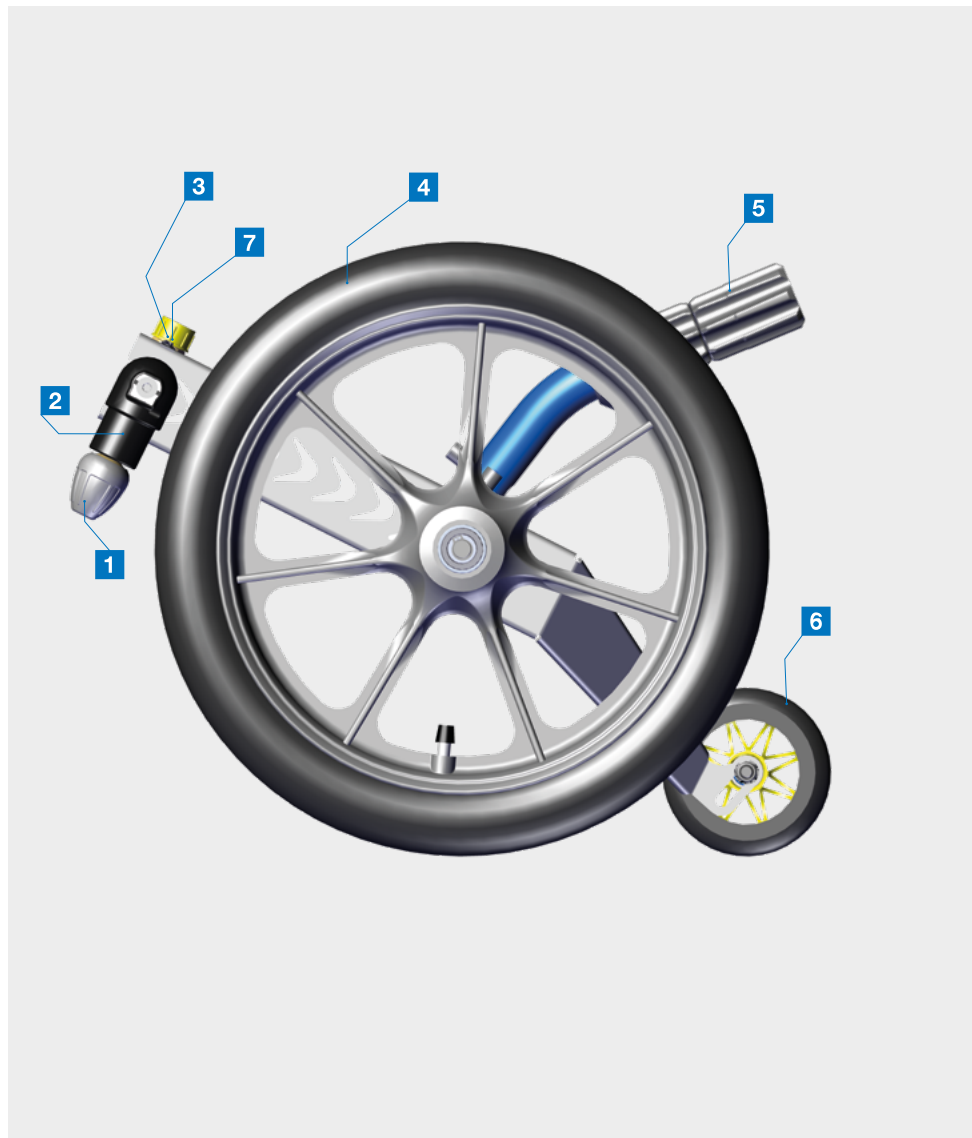



1 Rotor nozzle

2 Nozzle bar

3 M22x1.5-Aconnection

4 Wheel

5 Lance bow cranked

6 Support wheel

7 Protective cap

### Tool

Hex key size 4



Socket wrench size 8



Open-end wrench 25

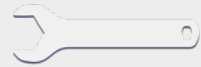

### Accessories required for operation

The lichen remover is part of a cleaning system. The accessories listed here are required for operation.

1

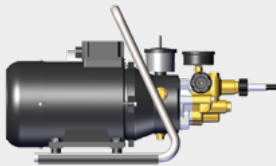

2



3

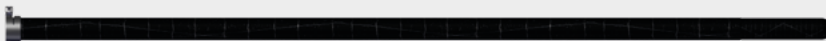

1 High pressure cleaner

2 High pressure hose NW6

3 Modular bar VCMO



### How does the lichen remover work?

The lichen remover removes dirt and incrustations using rotor nozzles. The nozzle openings of the rotary nozzle have a particularly small diameter and produce a needle-like jet of water that softens and removes hard incrustations.

The rotor nozzles are mounted on a replaceable nozzle bar, which is supplied with high-pressure water via an NW6 high-pressure hose.

The high-pressure hose is attached to the VCMO modular bar so that it does not lie on the floor in the area of movement.

The lichen remover can be controlled using the VMCO modular pole and the cranked lance arch.

The support wheel limits the distance of the recoil force of the rotor nozzles during nozzle operation. This means that the cleaning distance always remains the same.



Rotor nozzles

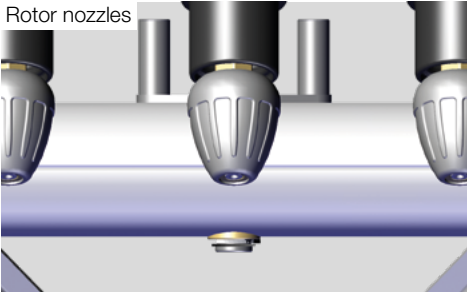

### Components and their function

**The rotor nozzles** generate a rotating spot jet.

**The nozzle bar** is the base for the rotor nozzles and supplies the pressurised water.

Nozzle bar

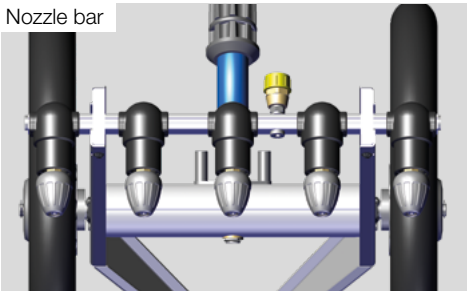

**The M22x1.5 connection** is the access for the pressurised water at the nozzle bar.

**The wheel** ensures flexible manoeuvrability.

**The lance bow** together with the modular rod VCMO is the control lever.

M22x1.5 connection + protective cap

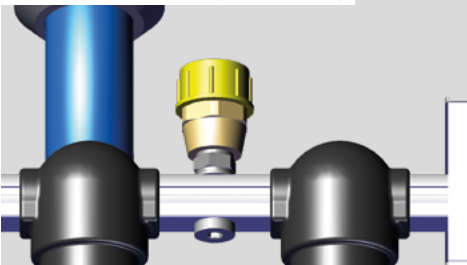

**The support wheel** is the limit stop for the maximum cleaning distance.

Wheel



Lance bow



Support wheel

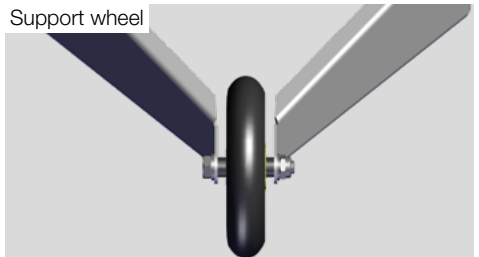



## Intended use

Here you will find the following information:  
For what purposes may the cleaner be used?  
Where may the cleaner be used? Who is  
allowed to use the cleaner?



### **Intended use**

The lichen remover is intended exclusively for cleaning work on surfaces. The surfaces must be suitable for cleaning with a hard spot jet. Do not use it to clean organic surfaces. If it is not clear whether a surface is suitable for cleaning with a hard spot jet, this must be tested on a test section.

The lichen remover may only be connected to pressure washers that comply with the EN 60335-2-79 standard and are compatible with the specified technical data. This particularly includes the permissible operating pressure (bar), flow rate (l/min), water temperature (°C), and the appropriate connection type. Any other use is not an intended use.

### **Requirements of the system user**

**Operator:** The operator must be instructed by the plant operator in the assigned tasks and possible dangers in case of improper conduct. The operator may only carry out tasks that go beyond normal operation if this is indicated in this manual and the plant operator has expressly instructed them to do so.

**Qualified personnel:** Due to their technical training, knowledge, experience and familiarity with the relevant standards and regulations, qualified personnel are able to carry out the work assigned to them, recognise possible dangers and avoid risks independently.

The following groups of people must not use the lichen remover:

- ▶ Persons with limited physical or mental capacities, respectively Skills
- ▶ Children and young people under the age of 18
- ▶ People who have not received instruction

### **Space requirements**

- ▶ Space required for storage: 0.6 x 0.5 x 0.5 metres.
- ▶ The following work surface is required: 2.0 x 2.0 metres.
- ▶ To assemble the system, an area of 2 x 2 metres is required.
- ▶ Movement space around the operator: 5 m<sup>2</sup>.
- ▶ To prevent accidents, the following work area must be surrounded by a safety zone of 20 metres to prevent access by unauthorised persons.

### **Performance data in normal operation**

The lichen remover has the following performance data:

- ▶ Working pressure between 100 and 120 bar
- ▶ Speed approx. 4,000 revolutions per minute
- ▶ Noise level in normal operation 96 decibels
- ▶ The maximum surface load generated



by the lichen remover is 0,14 Newton per square centimetre

### **Working width and weight**

- ▶ Working width: 400 mm
- ▶ Weight: 5.6 kg

### **Performance limits for operation**

- ▶ The lichen remover may be operated with maximum 120 bar.
- ▶ The lichen remover requires a volume flow of at least 10 litres per minute.
- ▶ The water temperature must not be higher than a temperature peak above 40 °C.

### **Water quality for operation**

- ▶ The lichen remover is to be operated with ultrapure water.
- ▶ The maximum conductance of the water must not be higher than 30  $\mu\text{S/cm}$  (20 ppm).

### **Requirements for the high-pressure cleaner**

- ▶ The high-pressure cleaner must have an operating pressure of 100-120 bar and a delivery rate of at least 10 l/min.



## EC Declaration of Conformity

Der Hersteller / Inverkehrbringer erklärt hiermit, dass folgendes Produkt

Produktbezeichnung: Flechtenentferner  
Modellbezeichnung: STR  
Handelsbezeichnung: 0201830 Flechtenentferner  
Baujahr: 2023  
Beschreibung: Flechtenentferner – Auswechselbare Ausrüstung für Oberflächen

Der Flechtenentferner ist eine auswechselbare Ausrüstung für Hochdruckreiniger, die vom Bediener nach Inbetriebnahme der Maschine angebracht werden kann, um die Reinigungsfunktion zu erweitern. Er eignet sich für die Reinigung von PV-Modulen, Dächern und Böden und entfernt Verschmutzungen gezielt mittels rotierender Punktstrahl Düsen.

Der Flechtenentferner darf nur an Hochdruckreiniger angeschlossen werden, die der Norm EN 60335-2-79 entsprechen und mit den angegebenen technischen Daten kompatibel sind. Dies betrifft insbesondere den zulässigen Betriebsdruck (bar), die Durchflussmenge (l/min), die Wassertemperatur (°C) sowie den passenden Anschluss.

allen einschlägigen Bestimmungen der angewandten Rechtsvorschriften (nachfolgend) - einschließlich derer zum Zeitpunkt der Erklärung geltenden Änderungen - entspricht. Die alleinige Verantwortung für die Ausstellung dieser Konformitätserklärung trägt der Hersteller. Diese Erklärung bezieht sich nur auf die Maschine in dem Zustand, in dem sie in Verkehr gebracht wurde; vom Endnutzer nachträglich angebrachte Teile und/oder nachträglich vorgenommene Eingriffe bleiben unberücksichtigt.

Folgende Rechtsvorschriften wurden angewandt: Maschinenrichtlinie 2006/42/EG  
Folgende harmonisierte Normen wurden angewandt:

EN 60335-2-79:2012	Sicherheit elektrischer Geräte für den Hausgebrauch und ähnliche Zwecke - Teil 2-79: Besondere Anforderungen für Hochdruckreiniger und Dampfreiniger (IEC 60335-2-79:2012 (modifiziert))
EN ISO 12100:2010	Sicherheit von Maschinen - Allgemeine Gestaltungsleitsätze - Risikobeurteilung und Risikominderung (ISO 12100:2010)
EN ISO 3744:2010	Akustik - Bestimmung der Schalleistungs- und Schallenergiepegel von Geräuschquellen aus Schalldruckmessungen - Hüllflächenverfahren der Genauigkeitsklasse 2 für ein im Wesentlichen freies Schallfeld über einer reflektierenden Ebene (ISO 3744:2010)
ISO/TR 14121-2:2012	Sicherheit von Maschinen - Risikobeurteilung - Teil 2: Praktischer Leitfaden und Methodenbeispiele

Name und Anschrift der Person, die bevollmächtigt ist, die technischen Unterlagen zusammenzustellen:  
Patrick Geiger-Pipornetti, TEV Jäger mbH, Grundweg 10  
89250 Senden

Ort: Senden Datum: 16.04.2026

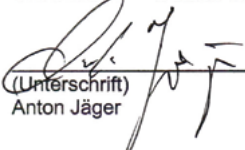
  
(Unterschrift)  
Anton Jäger

  
(Unterschrift)  
Patrick Geiger-Pipornetti



# General safety instructions

Important instructions for safe use of the system and for ensuring safe cleaning.



### For your safety

Important instructions for safe use of the system. These instructions enable you to protect yourself and others from dangerous situations and injuries.

#### **DANGER**



#### **Danger to life in severe weather conditions**

- ▶ Never work during a storm.  
This prevents the risk of being struck by lightning.

#### **DANGER**



#### **Risk of death from electric shock and high-voltage cables**

- ▶ The safety distance from the cleaning device to the high-voltage cable must not be less than **20 meters (65,6 ft)**. Failure to maintain the safety distance puts your life and health at risk.

#### **WARNING**



#### **Electric shock from photovoltaics**

- ▶ Cables and components of photovoltaic installations are always live during incidence of light.  
Touching live parts can lead to electric shock and is prohibited.

#### **WARNING**



#### **Electric shock due to defective photovoltaics**

- ▶ Check the modules for damage (cracks, scratches, leaks, etc.) prior to cleaning.  
Damaged modules must not be cleaned. There is a risk of injury due to electric shock.

#### **WARNING**



#### **Risk of injury from falling**

- ▶ Use a fall-arrest system.  
This will protect you from injuries from falling off the roof.



**CAUTION**



**Illness and hypothermia caused by bad weather**

- ▶ In bad weather, wear suitable protective clothing. This will protect you from illness caused by hypothermia.

**CAUTION**



**Hearing damage due to excessive noise**

- ▶ Use suitable hearing protection when working above a noise level of 85 dB(A). This protects your hearing from damage caused by high noise exposure.

**CAUTION**



**Risk of injury from overloading/strain**

- ▶ Take regular breaks. This will prevent injuries caused by physical and mental overload and fatigue.

**CAUTION**



**Risk of injury when lifting heavy parts**

- ▶ When lifting the machine, lift it ergonomically correctly. This will protect you from back-strain injuries.

**CAUTION**



**Risk of injury from flying dirt and parts**

- ▶ Wear safety goggles when working. This will protect you from injuries caused by flying dirt and loose parts.

**CAUTION**



**Risk of injury due to parts being flung away**

- ▶ Check the surface to be cleaned for objects before starting cleaning. This will protect you from injuries caused by parts being flung away.



**CAUTION**



**Skin injuries due to intense exposure to sunlight**

- ▶ Take care to protect your skin when exposed to intense sunlight. This is how you protect yourself from sunburn and the risk of skin cancer.

**NOTICE**

**Risk of damage due to frost**

- ▶ Prevent the machine from freezing up. Otherwise this could cause damage to the components. This will protect the machine from frost damage.



## Safe cleaning operation

Here you will find information about: choosing a safe cleaning location, sources of hazards in the working area, sources of hazards when working.



## Working safely

This section describes how to work safely with the lichen remover.

### Selecting a safe starting point

- ▶ In principle, the starting point for cleaning work is determined by the location and its accessibility.
- ▶ Before setting up, take a tour and consider how and where you can work safely.
- ▶ The starting point for cleaning must be easily accessible and safe.

### Awareness of hazards in the working area

- ▶ There must be **no high-voltage** conductive equipment (cables, switch cabinets, etc.) in the immediate working environment.

### Checking the safety of the modules to be cleaned

- ▶ When performing a visual inspection of the system, look out for defects in the system, e.g.
  - broken/defective solar modules
  - exposed cables
  - loose fastenings
  - etc.

### Safety when cleaning

- ▶ When cleaning, make sure that you do not damage any components or lines.

### Check and prepare the high-pressure equipment

- ▶ check the high-pressure connections for damage before starting work.
- ▶ check the high-pressure hose for damage and dirt on the quick connector before starting work.

### Cordon off access to the work area

- ▶ Block access to the area where your machines are located and the area where falling objects and machines would hit. Create a safe area in which no third party can come to harm.

## DANGER

### Risk of death from electric shock and high-voltage cables

- ▶ The safety distance from the cleaning device to the high-voltage cable must not be less than **20 meters (65,6 ft)**. Failure to maintain the safety distance puts your life and health at risk.



 **WARNING**

**Risk of injury from falling**

- ▶ Use a fall-arrest system. This will protect you from injuries from falling off the roof.

 **WARNING**

**Electric shock from photovoltaics**

- ▶ Cables and components of photovoltaic installations are always live during incidence of light. Touching live parts can lead to electric shock and is prohibited.

 **WARNING**

**Electric shock due to defective photovoltaics**

- ▶ Check the modules for damage (cracks, scratches, leaks, etc.) prior to cleaning. Damaged modules must not be cleaned. There is a risk of injury due to electric shock.

 **CAUTION**

**Risk of injury due to slippery surface**

- ▶ Check the surface for any situations that may facilitate slipping. This will protect you from falling and injuring yourself.

 **CAUTION**

**Risk of injury due to falling**

- ▶ Check your working area for unevenness and obstacles. This will protect you from injuries resulting from a fall.

 **CAUTION**

**Risk of injury due to defective hoses and connections**

- ▶ Check all high-pressure hoses and connections for damage. In this way you will protect yourself from injuries caused by a hard water jet that splashes out.

 **CAUTION**

**Risk of injury due to incorrect installation of the joints**

- ▶ Always hand-tighten and check the joints. This will protect you from injuries caused by uncontrolled flying joints.



# Commissioning the lichen remover

Here you will find information about how  
to prepare the cleaner for work.



## Unpacking

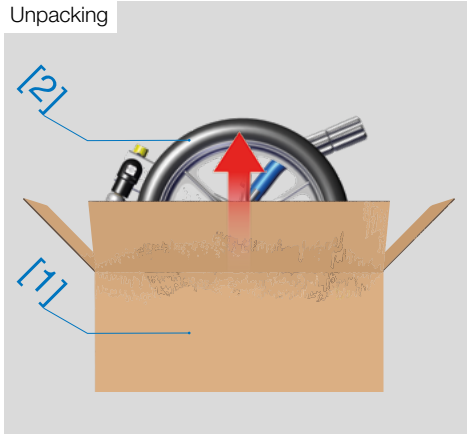

## Control

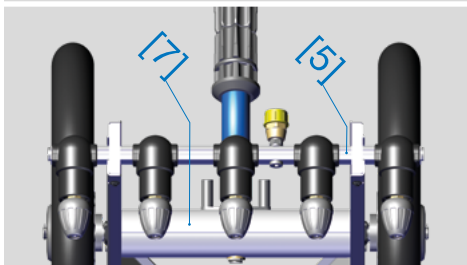
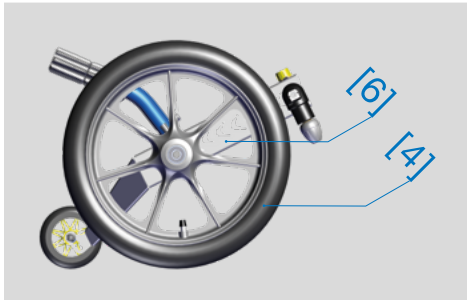
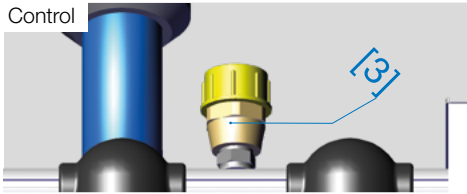

# Preparing to connect the cleaner

This step prepares the connection of the lichen remover.

## Unpacking the lichen remover

- ▶ Open the packaging [1] and remove the lichen remover [2].

## Check lichen remover

- ▶ Check for damage:
  - ▶ the M22x1.5 connection [3]
  - ▶ the wheels [4]
  - ▶ the nozzle bar [5]
  - ▶ the chassis [6]

## Transporting the cleaner to the place of use

- ▶ Plan in advance how you can transport the lichen remover to its place of use.
- ▶ Take into account possible transport aids with which you can transport safely.
- ▶ When carrying the cleaner, hold it only by the profile tube [7].



Mounting the lance

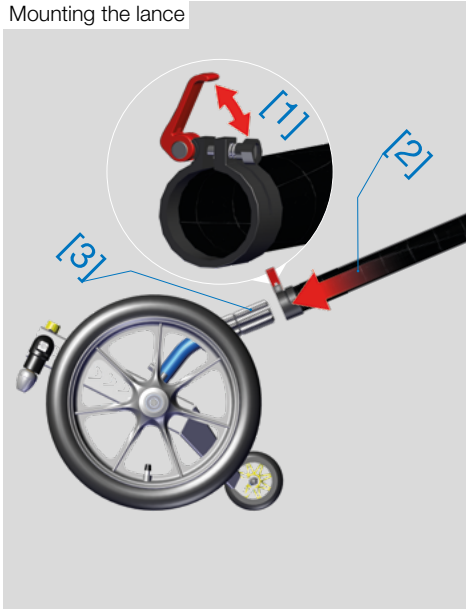

## Mounting the VCMO lance

- ▶ Open the tension clamp [1] on the rod and push the rod [2] onto the lance bow [3] as far as it will go.
- ▶ Close the tension clamp [1]
- ▶ Check whether the clamping of the tension clamp is sufficient. If the clamping is not sufficient, readjust the tensioning clamp.

## Connecting the high-pressure hose to the high-pressure cleaner

- ▶ Place the quick connector [4] on the high-pressure outlet [5] of the high-pressure cleaner [6].
- ▶ Tighten the high-pressure hose using the union nut of the quick-action screw connection.
- ▶ Take the free end of the high-pressure hose.

Connect the high-pressure cleaner

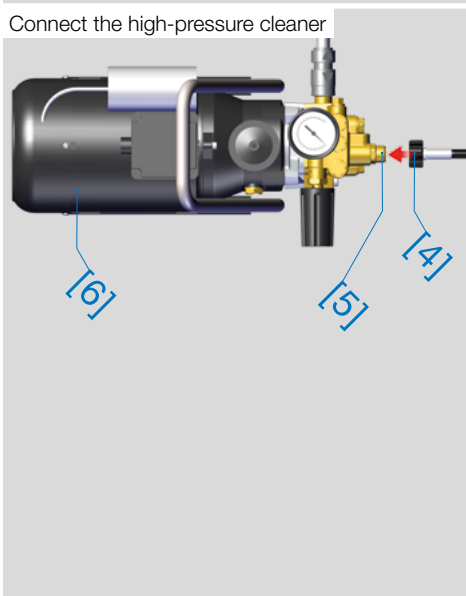

### **WARNING**

#### **Risk of injury due to incorrect adjustment of the bracket**

- ▶ The bracket must always clamp with sufficient force. This prevents personal injury and damage to property due to uncontrolled falling of parts.

### **CAUTION**

#### **Risk of injury when lifting heavy parts**

- ▶ When lifting the machine, make sure to lift it in an ergonomically correct way. This will protect you from injuries caused by overloading your back.



Flushing the high-pressure hose

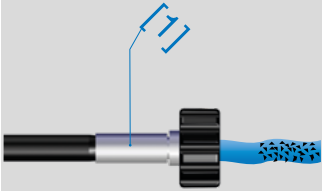

Fitting the NW6 high-pressure hose

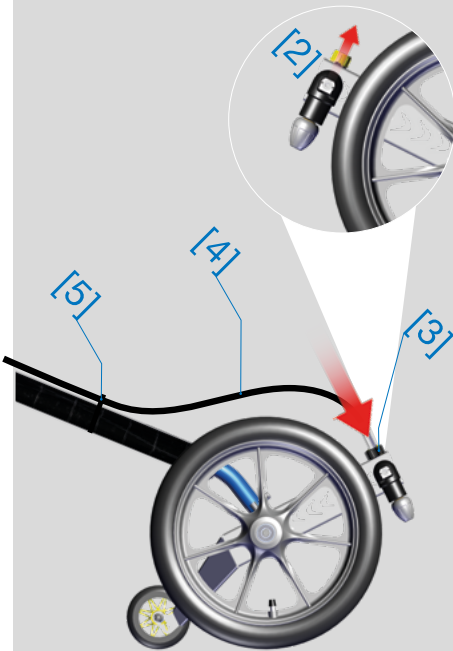

- ▶ Open the water supply and rinse the high-pressure hose [1] for approx. 1-2 minutes. This ensures that soiling from the high-pressure hose is not flushed into the lichen remover.
- ▶ Close the water supply again.

## Fitting the NW6 high-pressure hose

- ▶ Unscrew the protective cover [2] from the M22x1.5 connection [3].
- ▶ Screw the greased quick connector of the NW6 high-pressure hose [4] to the connection [3].
- ▶ Attach the high-pressure hose [4] to the holders [5] of your VCMO lance.

### ⚠ CAUTION

#### Risk of injury from uncontrolled start-up

- ▶ Do not switch on the high-pressure cleaner until you have the lance with the cleaner safely in your hand. This will prevent personal injury and damage to property due to uncontrolled start-up.

### ⚠ CAUTION

#### Risk of injury from defective hoses and connections

- ▶ Check all high-pressure hoses and connections for damage. This will protect you from being injured by escaping hard water jets.



Holding the lichen remover for setting

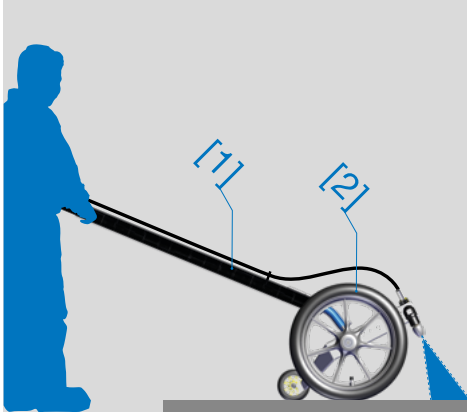

Switching on the high-pressure cleaner

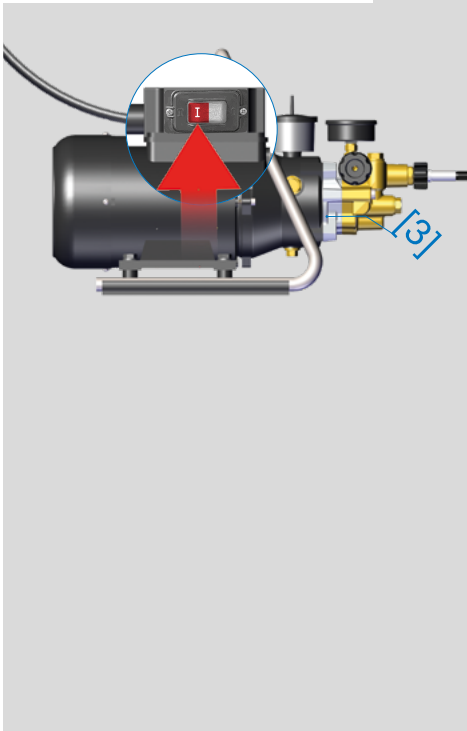

## Setting the pressure on the high-pressure cleaner

- ▶ Open the water supply and wait until the system is flooded.
- ▶ Position the lichen remover [2] with the VCMO rod [1] so that the pressure on the high-pressure cleaner [3] can be adjusted.
- ▶ Hold the lichen remover [2] over the VCMO rod [1] in position.
- ▶ Switch on the high-pressure cleaner [3].

### WARNING

#### Risk of injury due to sudden start-up

- ▶ Start and stop the machine only using a suitable system and not using the high-pressure cleaner.
- This will protect you from injuries caused by unintentional start-up.

### WARNING

#### Risk of injury due to excessive operating pressure

- ▶ Do not operate the machine above the specified maximum operating pressure.
- In this way you protect yourself from injuries caused by connecting parts being flung away in an uncontrolled manner.



Setting the operating pressure

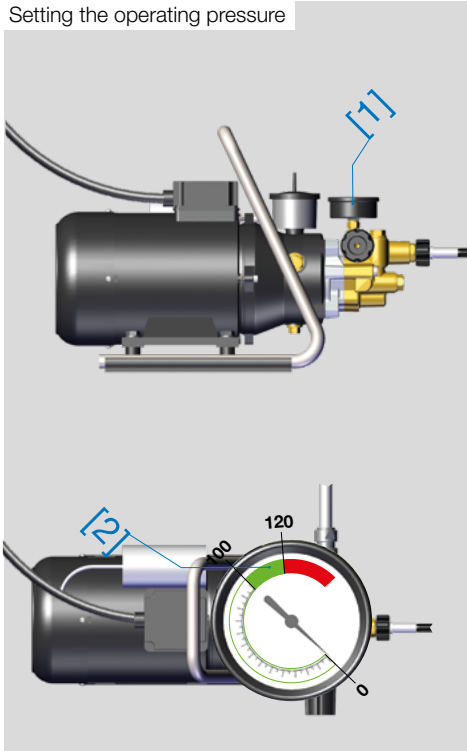

- ▶ Set the operating pressure [1] in the range of 100-120 bar.
- ▶ Switch off the high-pressure cleaner [2] again.

## Switching the high water pressure on/off

We offer two optional products to switch the high-pressure water from the work area on and off safely and conveniently:

- ▶ Switching high water pressure on/off with water stop [3]. *With the water stop, you can switch the high water pressure on and off via a ball valve close to the work area.*

### ⚠ CAUTION

#### Risk of injury to uninvolved persons

- ▶ Check whether unauthorised persons are in the work area. This will prevent personal injury due to collisions.

### ⚠ CAUTION

#### Risk of injury from ejected parts

- ▶ Wear full face protection. This protects you from injuries caused by ejected parts.

### ⚠ CAUTION

#### Risk of injury during installation

- ▶ Wear gloves during installation. This will protect your skin from abrasions and pinching.

Water stop





Radio remote control



► Switching high water pressure on/off with radio remote control [1]. *With our radio remote control, you can switch the high-pressure cleaner on and off directly.*

### Changing the nozzle bar

The nozzle bar can be removed for maintenance or spare parts installation.

- Use the hexagon socket size 4 to loosen [2] the four pan-head screws [3] on the chassis until the nozzle bar [4] can be moved.
- Drag the nozzle bar [4] forwards out of the chassis.
- Now insert the desired nozzle bar version into the chassis.
- Screw the 4 pan head screws [3] with 8 Nm.

Changing the nozzle bar

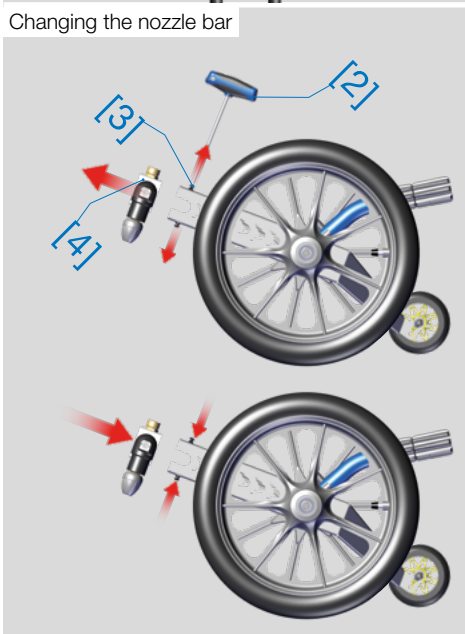

### NOTICE

#### Risk of damage due to jamming of threads and heavy wear of O-rings

- Grease high-pressure connections such as threads, O-rings and connections with a lubricating grease (DIN 51502: KP2G-30) before assembly.

Lubrication reduces the risk of jamming, heavy wear and the resultant damage.



**Notes**

Handwritten notes on a dotted grid background. The notes are written in blue ink and are organized into two columns. The left column contains the following text:

- 1. (C) (L) (P)
- 2. (C) (L) (P)
- 3. (C) (L) (P)
- 4. (C) (L) (P)
- 5. (C) (L) (P)
- 6. (C) (L) (P)
- 7. (C) (L) (P)
- 8. (C) (L) (P)
- 9. (C) (L) (P)
- 10. (C) (L) (P)
- 11. (C) (L) (P)
- 12. (C) (L) (P)
- 13. (C) (L) (P)
- 14. (C) (L) (P)
- 15. (C) (L) (P)
- 16. (C) (L) (P)
- 17. (C) (L) (P)
- 18. (C) (L) (P)
- 19. (C) (L) (P)
- 20. (C) (L) (P)
- 21. (C) (L) (P)
- 22. (C) (L) (P)
- 23. (C) (L) (P)
- 24. (C) (L) (P)
- 25. (C) (L) (P)
- 26. (C) (L) (P)
- 27. (C) (L) (P)
- 28. (C) (L) (P)
- 29. (C) (L) (P)
- 30. (C) (L) (P)
- 31. (C) (L) (P)
- 32. (C) (L) (P)
- 33. (C) (L) (P)
- 34. (C) (L) (P)
- 35. (C) (L) (P)
- 36. (C) (L) (P)
- 37. (C) (L) (P)
- 38. (C) (L) (P)
- 39. (C) (L) (P)
- 40. (C) (L) (P)
- 41. (C) (L) (P)
- 42. (C) (L) (P)
- 43. (C) (L) (P)
- 44. (C) (L) (P)
- 45. (C) (L) (P)
- 46. (C) (L) (P)
- 47. (C) (L) (P)
- 48. (C) (L) (P)
- 49. (C) (L) (P)
- 50. (C) (L) (P)
- 51. (C) (L) (P)
- 52. (C) (L) (P)
- 53. (C) (L) (P)
- 54. (C) (L) (P)
- 55. (C) (L) (P)
- 56. (C) (L) (P)
- 57. (C) (L) (P)
- 58. (C) (L) (P)
- 59. (C) (L) (P)
- 60. (C) (L) (P)
- 61. (C) (L) (P)
- 62. (C) (L) (P)
- 63. (C) (L) (P)
- 64. (C) (L) (P)
- 65. (C) (L) (P)
- 66. (C) (L) (P)
- 67. (C) (L) (P)
- 68. (C) (L) (P)
- 69. (C) (L) (P)
- 70. (C) (L) (P)
- 71. (C) (L) (P)
- 72. (C) (L) (P)
- 73. (C) (L) (P)
- 74. (C) (L) (P)
- 75. (C) (L) (P)
- 76. (C) (L) (P)
- 77. (C) (L) (P)
- 78. (C) (L) (P)
- 79. (C) (L) (P)
- 80. (C) (L) (P)
- 81. (C) (L) (P)
- 82. (C) (L) (P)
- 83. (C) (L) (P)
- 84. (C) (L) (P)
- 85. (C) (L) (P)
- 86. (C) (L) (P)
- 87. (C) (L) (P)
- 88. (C) (L) (P)
- 89. (C) (L) (P)
- 90. (C) (L) (P)
- 91. (C) (L) (P)
- 92. (C) (L) (P)
- 93. (C) (L) (P)
- 94. (C) (L) (P)
- 95. (C) (L) (P)
- 96. (C) (L) (P)
- 97. (C) (L) (P)
- 98. (C) (L) (P)
- 99. (C) (L) (P)
- 100. (C) (L) (P)

The right column contains the following text:

- 1. (C) (L) (P)
- 2. (C) (L) (P)
- 3. (C) (L) (P)
- 4. (C) (L) (P)
- 5. (C) (L) (P)
- 6. (C) (L) (P)
- 7. (C) (L) (P)
- 8. (C) (L) (P)
- 9. (C) (L) (P)
- 10. (C) (L) (P)
- 11. (C) (L) (P)
- 12. (C) (L) (P)
- 13. (C) (L) (P)
- 14. (C) (L) (P)
- 15. (C) (L) (P)
- 16. (C) (L) (P)
- 17. (C) (L) (P)
- 18. (C) (L) (P)
- 19. (C) (L) (P)
- 20. (C) (L) (P)
- 21. (C) (L) (P)
- 22. (C) (L) (P)
- 23. (C) (L) (P)
- 24. (C) (L) (P)
- 25. (C) (L) (P)
- 26. (C) (L) (P)
- 27. (C) (L) (P)
- 28. (C) (L) (P)
- 29. (C) (L) (P)
- 30. (C) (L) (P)
- 31. (C) (L) (P)
- 32. (C) (L) (P)
- 33. (C) (L) (P)
- 34. (C) (L) (P)
- 35. (C) (L) (P)
- 36. (C) (L) (P)
- 37. (C) (L) (P)
- 38. (C) (L) (P)
- 39. (C) (L) (P)
- 40. (C) (L) (P)
- 41. (C) (L) (P)
- 42. (C) (L) (P)
- 43. (C) (L) (P)
- 44. (C) (L) (P)
- 45. (C) (L) (P)
- 46. (C) (L) (P)
- 47. (C) (L) (P)
- 48. (C) (L) (P)
- 49. (C) (L) (P)
- 50. (C) (L) (P)
- 51. (C) (L) (P)
- 52. (C) (L) (P)
- 53. (C) (L) (P)
- 54. (C) (L) (P)
- 55. (C) (L) (P)
- 56. (C) (L) (P)
- 57. (C) (L) (P)
- 58. (C) (L) (P)
- 59. (C) (L) (P)
- 60. (C) (L) (P)
- 61. (C) (L) (P)
- 62. (C) (L) (P)
- 63. (C) (L) (P)
- 64. (C) (L) (P)
- 65. (C) (L) (P)
- 66. (C) (L) (P)
- 67. (C) (L) (P)
- 68. (C) (L) (P)
- 69. (C) (L) (P)
- 70. (C) (L) (P)
- 71. (C) (L) (P)
- 72. (C) (L) (P)
- 73. (C) (L) (P)
- 74. (C) (L) (P)
- 75. (C) (L) (P)
- 76. (C) (L) (P)
- 77. (C) (L) (P)
- 78. (C) (L) (P)
- 79. (C) (L) (P)
- 80. (C) (L) (P)
- 81. (C) (L) (P)
- 82. (C) (L) (P)
- 83. (C) (L) (P)
- 84. (C) (L) (P)
- 85. (C) (L) (P)
- 86. (C) (L) (P)
- 87. (C) (L) (P)
- 88. (C) (L) (P)
- 89. (C) (L) (P)
- 90. (C) (L) (P)
- 91. (C) (L) (P)
- 92. (C) (L) (P)
- 93. (C) (L) (P)
- 94. (C) (L) (P)
- 95. (C) (L) (P)
- 96. (C) (L) (P)
- 97. (C) (L) (P)
- 98. (C) (L) (P)
- 99. (C) (L) (P)
- 100. (C) (L) (P)



## Working with the lichen remover

Here you will find information about working with the cleaning system.



## Working with the lichen remover

Working with the lichen remover is described here:

- ▶ What do I need to be aware of when working with a rotor nozzle?
- ▶ Controlling the lichen remover

### What do I need to be aware of when working with a rotor nozzle?

The basic principle of a rotor nozzle is based on a pressurised, round jet of water that is set in rotation in the rotor nozzle. The pressurised water transfers the energy generated by the pressure washer to the surface to be cleaned. This makes it possible to break up and rinse off very hard soiling.

As the water jet is very powerful, attention must be paid to the following:

- ▶ Do not move too slowly over the areas to be cleaned. It is better to move over the spot several times.
- ▶ Do not remain in standstill at one point.
- ▶ Wear protective equipment as the loosened dirt will be cast away.
- ▶ No persons may be in the work area without protective equipment.

### CAUTION

#### Risk of injury to uninvolved persons

- ▶ Check whether unauthorised persons are in the work area. This will prevent personal injury due to collisions.

### CAUTION

#### Risk of injury from ejected parts

- ▶ Wear full face protection. This protects you from injuries caused by ejected parts.

### WARNING

#### Risk of injury due to sudden start-up

- ▶ Start and stop the machine only using a suitable system and not using the high-pressure cleaner. This will protect you from injuries caused by unintentional start-up.



Positioning the cleaner

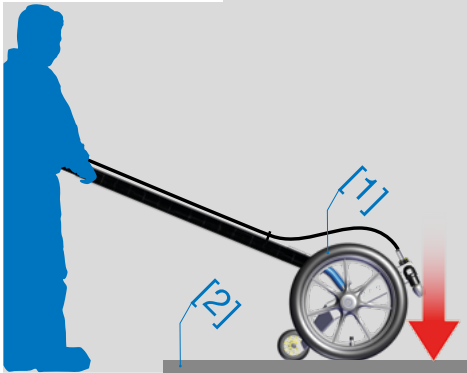

Starting the cleaner

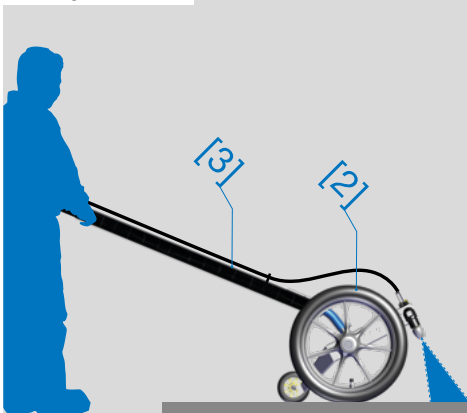

Switching on the high water pressure

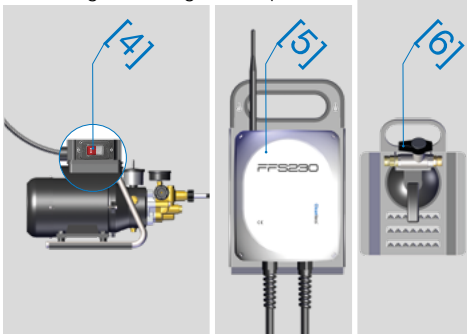

## Apply the lichen remover

- ▶ Place the lichen remover [1] on the module to be cleaned [2].
- ▶ Make sure to apply the lichen remover gently to the surface to be cleaned.

## Start lichen remover

- ▶ Hold the lichen remover [2] over the VCMO rod [3] in position.
- ▶ Switch on the high-pressure cleaner [4] – on the device, on the radio remote control [5] or release the high water pressure via the water stop [6] .

*Please note: The chassis of the lichen remover tips onto the support wheel when the pressure washer is started.*

### WARNING

#### Risk of injury from falling parts

- ▶ Check the surface to be cleaned for parts that could fall. In this way you will protect yourself and other persons from injury from falling parts.

### WARNING

#### Risk of injury from falling

- ▶ Use a fall-arrest system. This will protect you from injuries from falling off the roof.



Steering lichen remover

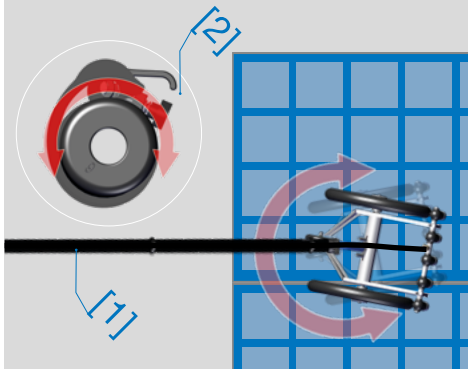

Operating movement

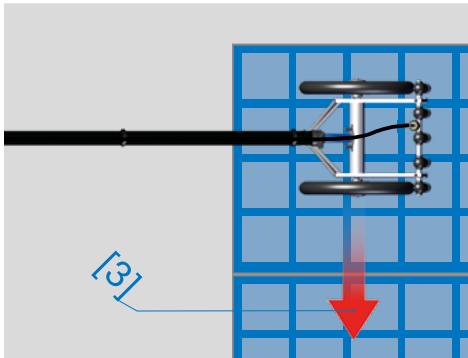
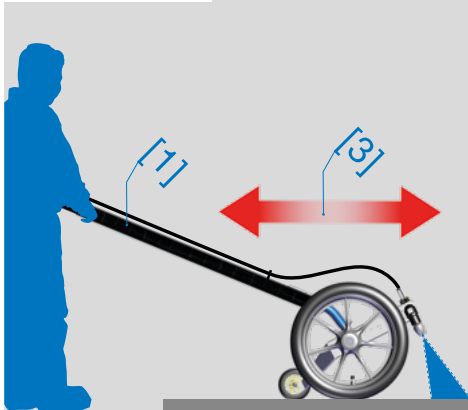

## The cleaning process

- ▶ Direct the lichen remover [1] by rotating the VCMO rod [2] to the area to be cleaned.
- ▶ Run the lichen remover [1] with a steady motion [3] over the areas to be cleaned.
- ▶ Repeat the process if necessary.

*Please note: Do not move too slowly over the area to be cleaned.*

### CAUTION

#### Risk of injury to uninvolved persons

- ▶ Check whether unauthorised persons are in the work area. This will prevent personal injury due to collisions.

### CAUTION

#### Risk of injury due to falling

- ▶ Check your working area for unevenness and obstacles. This will protect you from injuries resulting from a fall.

### CAUTION

#### Risk of injury due to slippery surface

- ▶ Check the surface for any situations that may facilitate slipping. This will protect you from falling and injuring yourself.



Stopping the cleaner

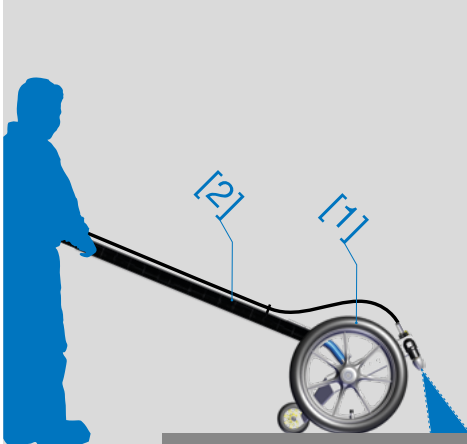

## Stop lichen remover

- ▶ Hold the lichen remover [1] over the VCMO rod [2] in position.
- ▶ Switch off the high-pressure cleaner [3] – on the device, on the radio remote control [4] or block the high water pressure at the water stop [5].

*Please note: The chassis of the lichen remover tilts forwards when the pressure washer is stopped.*

## Pause cleaning

- ▶ To pause the work, tilt the lichen remover [1] onto the side [6].
- ▶ Make sure that it cannot slip.

Switching on the high water pressure

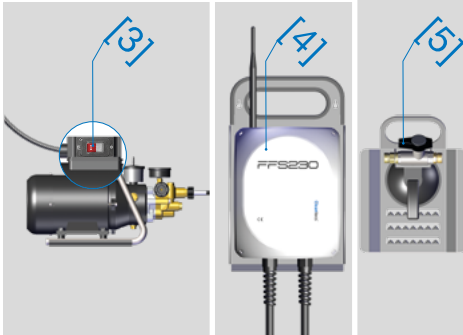

Pause cleaning

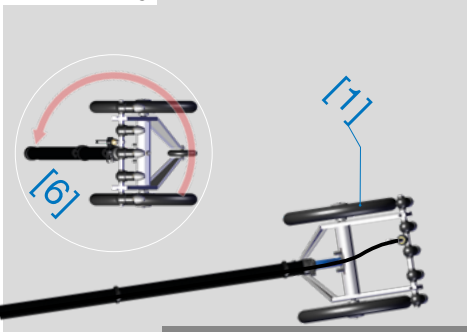

## ⚠ WARNING

### Risk of injury from falling cleaner

- ▶ When working at the edge of the work area, be careful not to go too far over the edge.

In this way you will avoid personal injury and damage to property caused by a falling cleaner.

## ⚠ CAUTION

### Risk of injury from falling machine

- ▶ Check the correct position of the machine.
- This will protect you from injuries caused by the machine falling.



## Take the lichen remover out of operation

Information about disassembling the cleaning system can be found [here](#).



Dismantle NW6 high-pressure hose

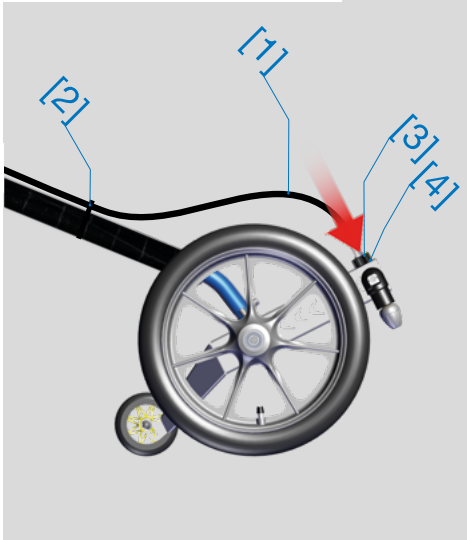

## Dismantling the lichen remover

The disassembly of the lichen remover is described here: All disassembly work must be carried out with the high-pressure cleaner switched off!

### Dismantling the NW6 high-pressure hose

- ▶ Connect the water supply to the pressure washer.
- ▶ Detach the high-pressure hose [1] at the holders [2] of your VCMO lance.
- ▶ Loosen the quick connector of the NW6 high-pressure hose [3] on the connection [4] and unscrew it.
- ▶ Screw on the protective cover [5] onto the M22x1.5 connection [4].

Dismantling the lance

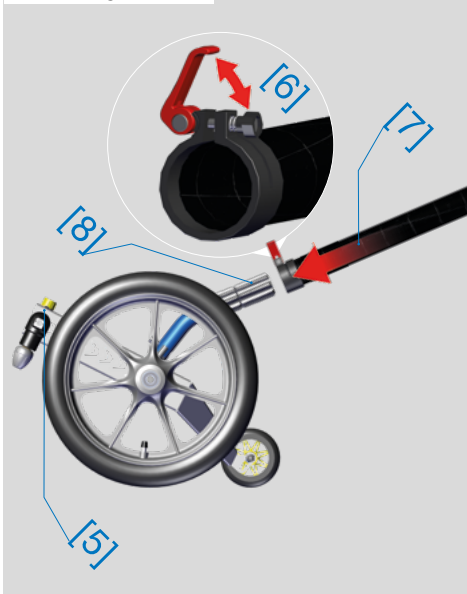

### Dismantling the VCMO lance

- ▶ Open the tension clamp [6] on the rod and pull the rod [7] out of the lance bow [8].
- ▶ Close the tension clamp [6].

### CAUTION

#### Risk of injury during disassembly

- ▶ Wear gloves during disassembly. This will protect your skin from abrasions and pinching.



Remove high-pressure cleaner

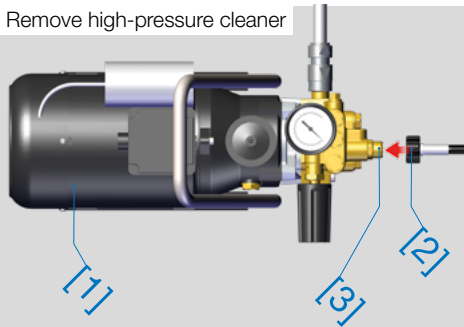

### Remove the high-pressure hose from the high-pressure cleaner

- ▶ Loosen the high-pressure hose using the union nut of the quick connector [2] and unscrew it from the connection [3].

### Transporting lichen remover from the roof

- ▶ Plan in advance how you will transport the cleaner from its place of use.
- ▶ Consider possible transport aids with which you can support the transport safely and without endangering yourself, third parties or the cleaner.
- ▶ When carrying the cleaner, only hold the machine by the profile tube [4].

Carry lichen remover

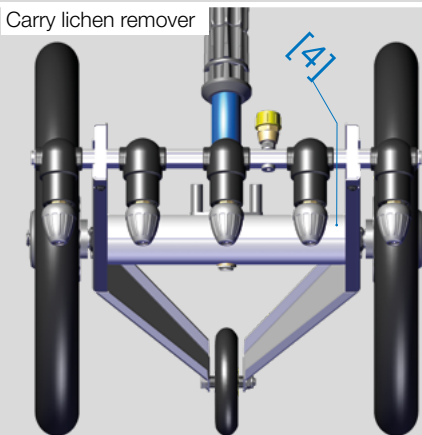

### WARNING

#### Risk of injury from falling

- ▶ Use a fall-arrest system. This will protect you from injuries from falling off the roof.

### CAUTION

#### Risk of injury to uninvolved persons

- ▶ Check whether unauthorised persons are in the work area. This will prevent personal injury due to collisions.



# Transport and storage

Here you will find information about transporting and storing the system.



Remove water

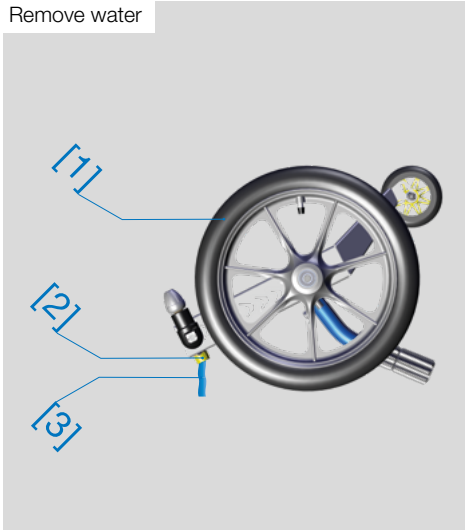

Blow out water

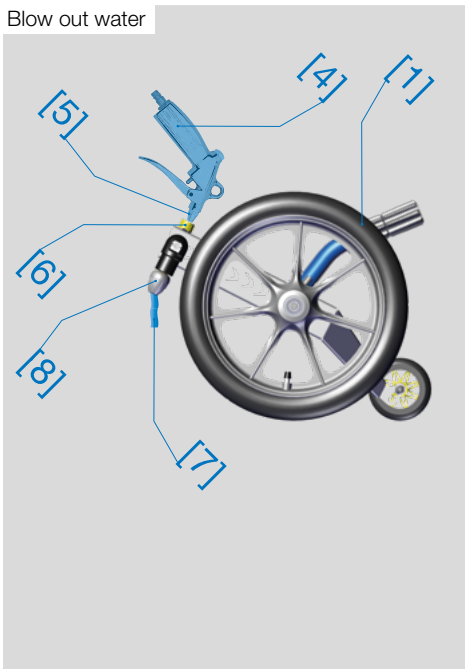

## Transporting and storing the cleaner

This section explains how to transport and store the cleaner safely and without damage.

### Allow water to run out of the cleaner

- ▶ Hold the lichen remover [1] with the opening of the connection [2] towards the floor. Allow the water [3] run out until it just drips [2]
- ▶ Take a compressed air gun [4], set the output [5] of the gun to the M22x1.5 connection [6] of the lichen remover [1].
- ▶ Blow the compressed air into the lichen remover until there is no water [7] from the rotor nozzles [8] coming out.
- ▶ Screw the yellow protective cap onto the connection.

### NOTICE

#### Risk of frost damage

- ▶ Do not expose the machine to frost. Frost can damage the components. Avoiding frost protects the machine from damage caused by frozen water.



### Component check

Check all components for damage, especially those components that are part of the high-pressure water supply. Replace defective components. This means you can start working with the lichen remover again without delay the next time you use it.

### Cleaner care

Clean the system thoroughly to remove dirt that collects in day-to-day operation.

Cleaning:

- ▶ Solvent-based cleaners (brake cleaner) for aluminium and plastic surfaces.

### Preserving the cleaner

To protect and maintain the system over the storage period, preserve the components before storing them.

Preservation:

- ▶ A spray oil for the aluminium surfaces.
- ▶ A silicone oil for the plastic surfaces.

### Lubricating components

The following parts must be lubricated:

- ▶ Regrease the connection (DIN 51502: KP2G-30).
- ▶ Grease all O-rings and threads of the quick-release fittings on the high-pressure hoses and plugs.

### Making the cleaner winterproof

- ▶ Remove the water inside as described on **Page 42**.
- ▶ Preserve the cleaner as described on the **left**.
- ▶ Store the lichen remover in a place protected from the elements.

### Making the cleaner winterproof

- ▶ Transport the lichen remover lying on its side. This prevents it from rolling uncontrollably.

#### CAUTION

#### Risk of injury due to defective hoses and connections

- ▶ Check all high-pressure hoses and connections for damage. In this way you will protect yourself from injuries caused by a hard water jet that splashes out.

#### CAUTION

#### Risk of injury during installation

- ▶ Wear gloves during installation. This will protect your skin from abrasions and pinching.

#### CAUTION

#### Risk of injury during disassembly

- ▶ Wear gloves during disassembly. This will protect your skin from abrasions and pinching.



## Repairing the lichen remover

Here you will find information on repairing the rotor nozzle and the HP filter.



Position the lichen remover

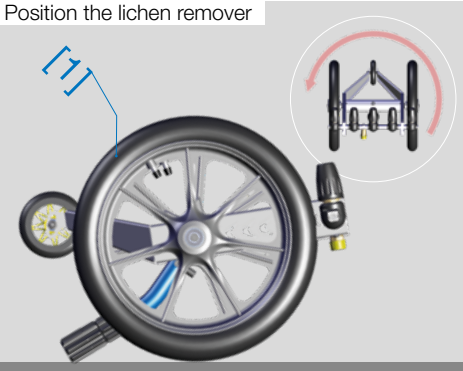

Attach the open-end spanner

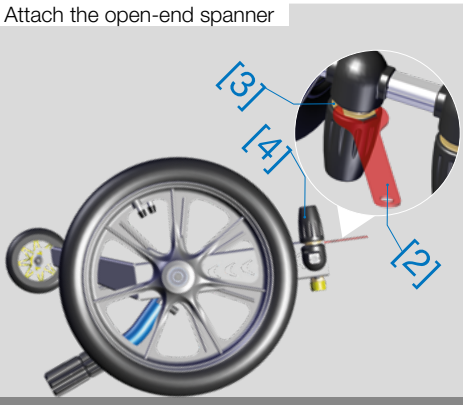

Unscrew the rotor nozzle

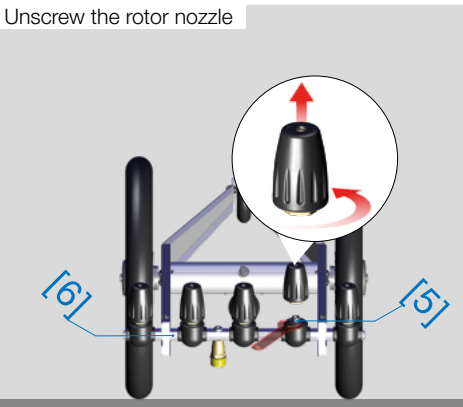

## Rotor nozzle defective

### Occurring error patterns

- ▶ No uniform cone
  - » Nozzle or bearing defective
- ▶ Uneven rotation speed
  - » Nozzle or bearing worn
- ▶ Rotor nozzle has strong vibrations
  - » Rotor defective
- ▶ No rotation of the spot beam
  - » Nozzle or bearing worn
  - » Nozzle clogged

### Corrective measure

- ▶ If the nozzle or bearing is defective, clogged or worn, the rotor nozzle must be replaced or the rotor and a new bearing unit installed.

## Replace rotor nozzle

### Dismantle the rotor nozzle from the nozzle bar

- ▶ Turn the lichen remover [1] 180° upside down.
- ▶ Take the supplied open-end spanner 25 [2] and place it on the hexagon [3] of the rotor nozzle [4].
- ▶ Loosen the rotor nozzle and unscrew it from the connection [5] of the nozzle bar [6].



Screw on the rotor nozzle

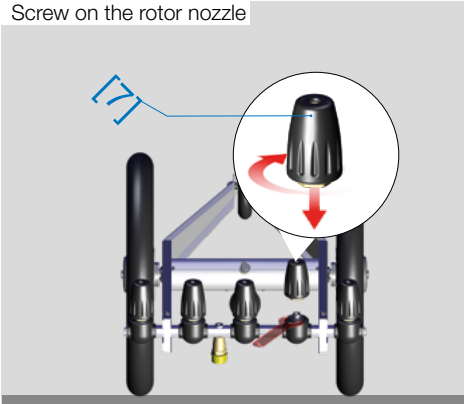

- ▶ Take the replacement rotor nozzle [7] and screw it onto the connection of the nozzle bar.
- ▶ Take the open-end spanner and tighten the rotor nozzle via the hexagon.

**⚠ CAUTION****Risk of injury during disassembly**

- ▶ Wear gloves during disassembly. This will protect your skin from abrasions and pinching.

Attach the open-end spanner

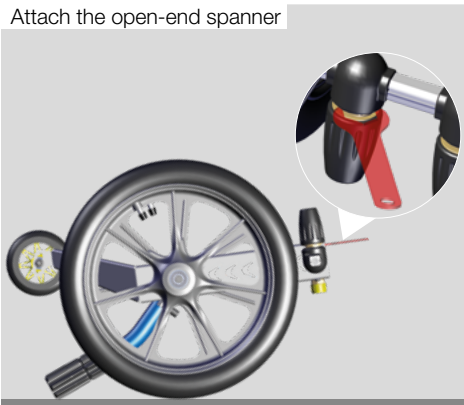



Fix the rotor nozzle in the vice

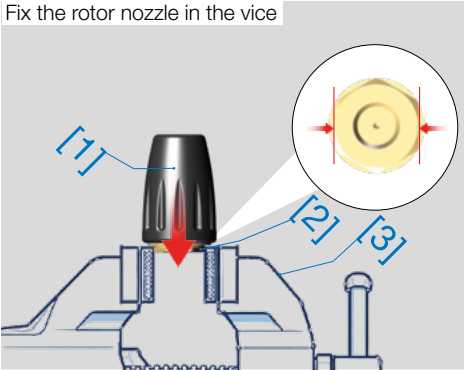

Remove the protective cap

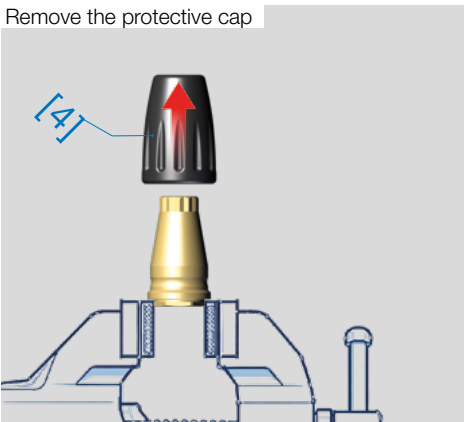

Attach ring spanner

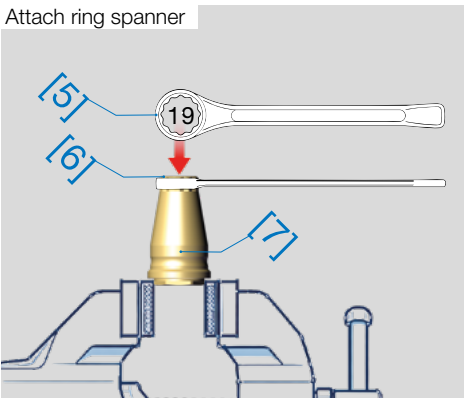

## Install repair kit

To install the repair kit, you must have dismantled the rotor nozzle as described under "Replace rotor nozzle".

### Open the pressurised housing

- ▶ Fix the rotor nozzle [1] with the hexagon of the drive plug [2] in a vice [3] (or a tool with spanner size 24).
- ▶ Remove the protective cap [4].
- ▶ Place the ring spanner with width 19 [5] on the spline [6] of the pressure housing [7].
- ▶ Unscrew the pressure housing from the drive plug.

### CAUTION

#### Risk of injury during installation

- ▶ Wear gloves during installation. This will protect your skin from abrasions and pinching.



Remove the pressure housing

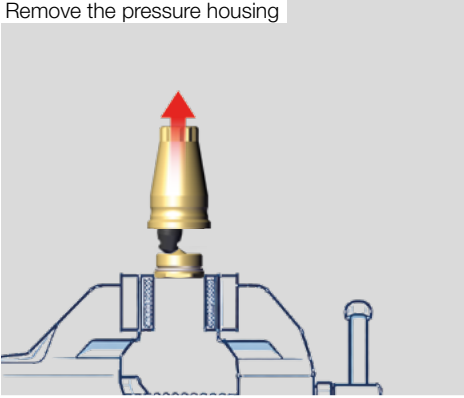

Remove rotor

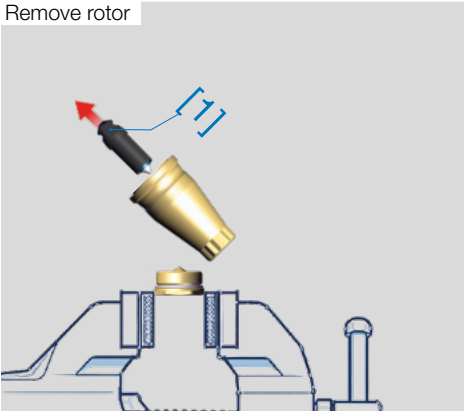

Remove storage unit

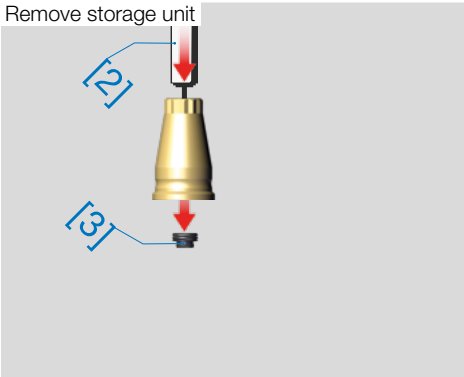

## Dismantle rotor and bearing

- ▶ Remove the old rotor [1] from the pressure housing.
- ▶ Take the assembly aid [2] and press the bearing unit [3] from outside to inside out of the pressure housing.

TIP - instead of the mounting aid, you can also use a round material with the diameter of the hole in the pressure housing.

- ▶ Clean any dirt from the pressure housing.

## ⚠ CAUTION

### Risk of injury during disassembly

- ▶ Wear gloves during disassembly. This will protect your skin from abrasions and pinching.



O-ring greasing

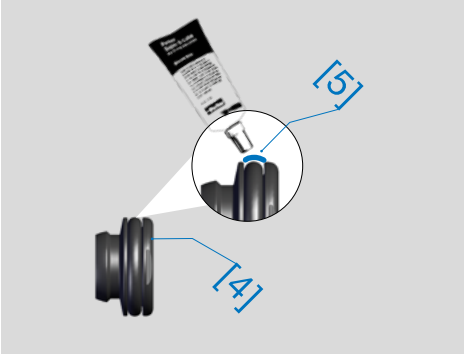

Place the bearing unit on the mounting aid



Insert storage unit

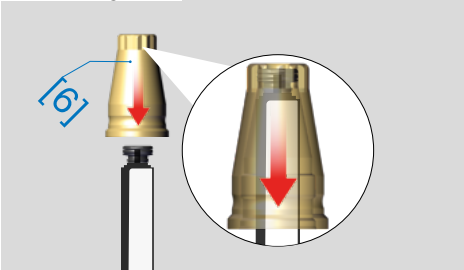

Insert rotor

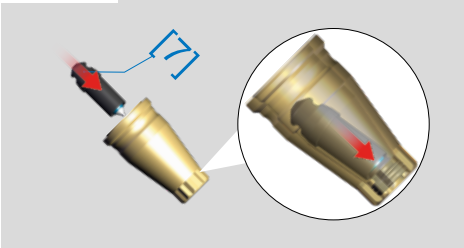

## Fitting the rotor and bearing

- ▶ Take the new bearing unit [4] and grease the O-ring [5].
- ▶ Place the bearing unit on the mounting aid with the bearing seat facing forward. TIP - instead of the mounting aid, you can also use a biro, for example.
- ▶ Slide the pressure housing [6] over the assembly aid in your hand and press the bearing unit down to the base of the pressurised housing.
- ▶ Take the new rotor [7] and place it in the pressure housing with the nozzle forward.
- ▶ Shift the rotor until it rests correctly in the bearing unit.

### CAUTION

#### Risk of injury during installation

- ▶ Wear gloves during installation. This will protect your skin from abrasions and pinching.



O-ring greasing

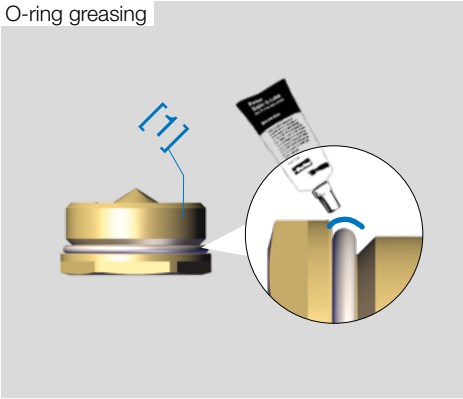

### Close pressure housing

- ▶ Remove the drive plug [1].
- ▶ Clean the drive plug.
- ▶ Grease the O-ring [2].
- ▶ Hold the pressure housing [3] vertically with the opening facing upwards.
- ▶ Screw the drive plug into the pressure housing as far as it will go.

CAUTION - the rotor must not become jammed.

Fitting the drive plug

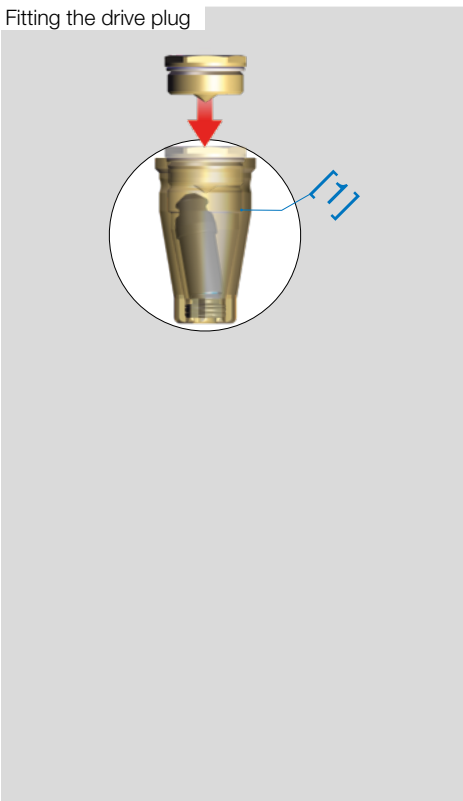

- ▶ Tighten the pressure housing with 25 Nm.



Remove the protective cap

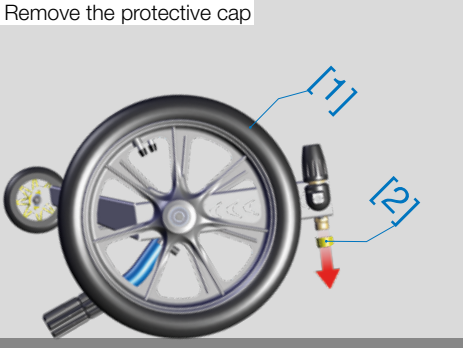

Dismantling the HP filter

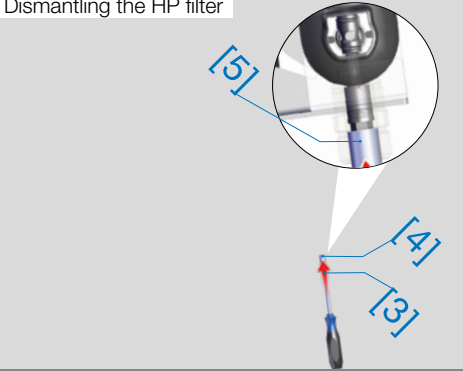

## Cleaning or replacing the HP filter

This explains how to dismantle, clean or replace the HP filter in the high-pressure connection of the lichen remover. You will need a socket spanner for this work.

### Dismantling the HP filter

- ▶ Turn the lichen remover [1] 180° upside down.
- ▶ Unscrew the protective cap [2].
- ▶ Take the socket spanner 8 [3].
- ▶ Insert the socket spanner into the HP connection [4] as far as it will go HP filter [5].
- ▶ Turn the socket spanner until the hexagon engages.
- ▶ Unscrew the HP filter from the connection.
- ▶ Hold the HP filter under running water. Check the HP filter for damage or heavy soiling. Replace it if necessary.

### Fitting the HP filter

- ▶ Take the cleaned or new HP filter.
- ▶ Place the HP filter on the sockets in the hexagon.
- ▶ Insert the fitted HP filter into the high-pressure connection using the socket spanner.
- ▶ Screw in the HP filter and turn until finger tight.
- ▶ Finally, screw the protective cap back onto the HP connection to protect it from dirt.



## Disposing of the system

Here you will find information about the disposal of the product and the associated components.



# What happens to the waste?

## Packaging

▶ The packaging is made of cardboard and can be disposed of with waste paper.

## Resin for ultra-pure water production

▶ Please refer to the safety data sheet for disposal regulations.

## Wheels, rotor nozzle covers, rotor nozzle holder housing

▶ These components can be disposed of with non-recyclable waste.

## Profile tube, lance connection, sheet metal parts, rotor nozzle, connection nipple

▶ These components can go into metal recycling.

### CAUTION

#### Risk of injury during disassembly

▶ Wear gloves during disassembly. This will protect your skin from abrasions and pinching.



**Notes**

Handwriting practice area with a grid of blue dots. The grid is approximately 20 columns wide and 30 rows high. On the left side, there are two vertical lines of dots, each starting with a small box containing the letter 'K'. The first line of dots is labeled 'K' and the second line is labeled 'L'.



Notes

Handwriting practice grid with a dotted pattern and a vertical margin line on the left side.

